

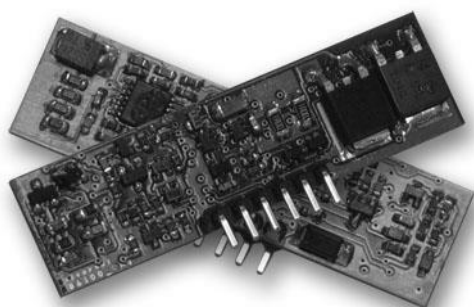

# Ag6110

Ultra POE Power-Sourcing-Equipment  
Module



## 1. Features

- Compliant with Ultra PoE IEEE802.3at Type 1 (af) & Type 2
- Small SIL package size - 53mm (L) x 14mm (H)
- Low cost
- Output power up to 74W
- Minimal (low cost) external components required
- Over-current and short circuit protection
- Silvertel "design-in" assistance

## 2. Description

The Ag6110 is part of the Ag6100 series offering a single output Power Sourcing Equipment (PSE) module designed for use with Ultra PoE, IEEE802.3at Type 1 (af) and Type 2 Power over Ethernet (PoE) applications.

The Ag6110 is pin compatible with the Ag6100 module offering up to 74W at its output and is aimed at applications requiring PSE functionality such as CCTV DVR, home networking and industrial Ethernet.

Ag6110 is a self-contained module, requiring just a few external components to provide a great deal of control and feedback over each Powered Device (PD) that is connected to the PSE.

## Table of Contents

1.	Features .....	1
2.	Description.....	1
	Table of Contents .....	2
	Table of Figures .....	2
3.	Ag6110 Product Selector.....	3
4.	Pin Description .....	4
5.	Functional Description .....	4
	5.1 Power Supplies.....	4
	5.2 Port Output .....	5
6.	Signature and Classification .....	6
	6.1 Signature Detection .....	7
	6.2 Classification .....	7
	6.3 Maintain Power Signature .....	8
	6.4 Output Current Limits .....	8
	6.5 Output Power.....	8
	6.6 High Power Options.....	9
7.	STATUS Output.....	10
8.	Protection .....	13
	8.1 Input Protection .....	13
	8.2 Output Short-Circuit Protection.....	13
9.	Electrical Characteristics .....	13
	9.1 Absolute Maximum Ratings <sup>1</sup> .....	13
	9.2 Recommended Operating Conditions.....	13
	9.3 Electrical Characteristics .....	14
10.	Package .....	15

## Table of Figures

Figure 1:	Block Diagram .....	3
Figure 2:	Ag6110 Package Format .....	3
Figure 3:	Power Supply Connections.....	4
Figure 4:	Typical Connection Diagram.....	5
Figure 5:	Signature, Class and Turn-On Timing - Type 1 PD .....	6
Figure 6:	Signature, Class and Turn-On Timing - Type 2 PD .....	6
Figure 7:	Signature Cycle Time .....	7
Figure 8:	Ag6110 Typical High Power Application Drawing .....	9
Figure 9:	STATUS Output at Port Connect and Disconnect .....	10
Figure 10:	STATUS Output when a Short Circuit is applied to the Output Port .....	10
Figure 11:	STATUS Output when an Over-Current is applied to the Output Port .....	11
Figure 12:	STATUS Output when an Over-Current fault is not removed .....	11
Figure 13:	STATUS Output LED drive circuit.....	12

## 3. Ag6110 Product Selector

Part Number†	Maximum Output Power (W) <sup>1</sup>	Marking
Ag6110*	74	H

† The Ag6110 fully meets the requirements of the RoHS directive 2002/95/EC on the restriction of hazardous substances in electronic equipment.

\* The Ag6110 uses the same PCB as the Ag6100 module

<sup>1</sup> Typical Operating power with a 57V power supply- not guaranteed.

Table 1: Ordering Information

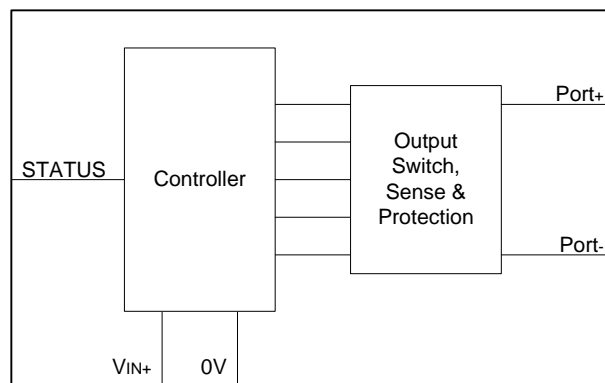

Figure 1: Block Diagram

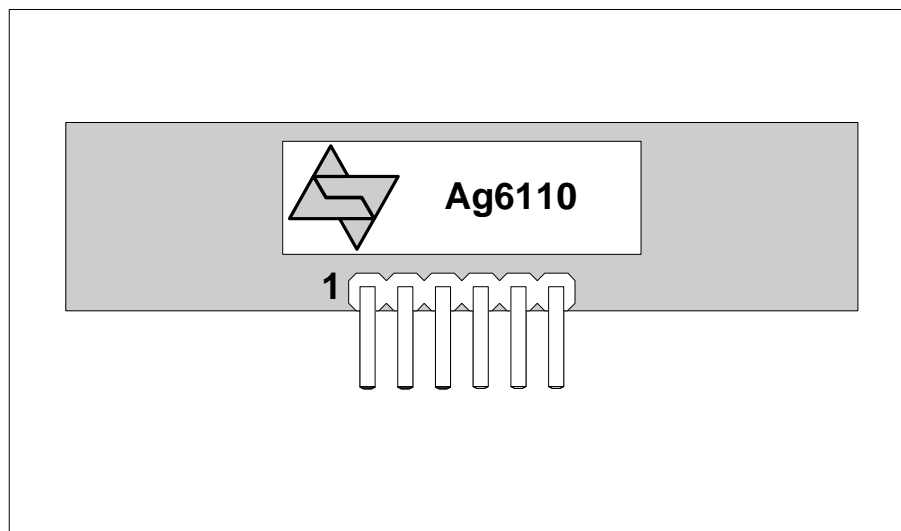

Figure 2: Ag6110 Package Format

## 4. Pin Description

Pin #	Name	Description
1	V <sub>IN+</sub>	<b>Main Power Supply.</b> This pin connects to an isolated 45V to 57V supply; relative to the 0V.
2	0V	<b>0V.</b> This pin is the return path for the isolated V <sub>IN+</sub> power supply.
3	STATUS	<b>Status Output.</b> This output shows the status of the Ag6110.
4	Port+	<b>Port Output.</b> This output pin monitors the line and supplies power to valid powered device.
5	Port-	<b>Port Output Return.</b> This pin is the return path for Port+.
6	NC	<b>No Connection.</b>

## 5. Functional Description

### 5.1 Power Supplies

The Ag6110 only requires one power supply; to conform to the IEEE802.3at specification, this supply must be isolated from mains ground, as shown in Figure 3.

Due to the power supply being capable of supplying up to 100W of power we would highly recommend protection in the form of a fuse to be fitted to positive input rail of the Ag6110. This will help prevent damage to the Ag6110 during an over voltage or over current event.

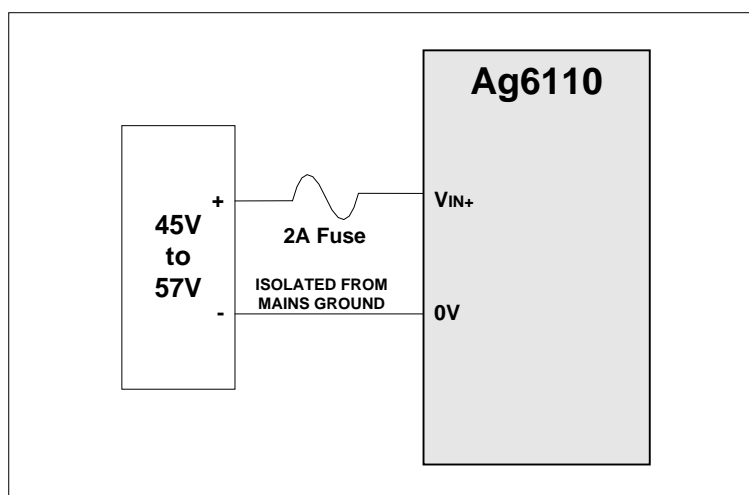

Figure 3: Power Supply Connections

## 5.2 Port Output

The Port output can be connected directly to the centre-tap of an IEEE802.3at compliant data transformer or to the spare pair connection for 10/100BASE-T applications, as shown in Figure 4. For 1000BASE-T (Gigabit) Ethernet applications all four cable pairs require magnetics, this is explained in more detail in application note “ANX-1000BASE-T-CONNECTIONS”.

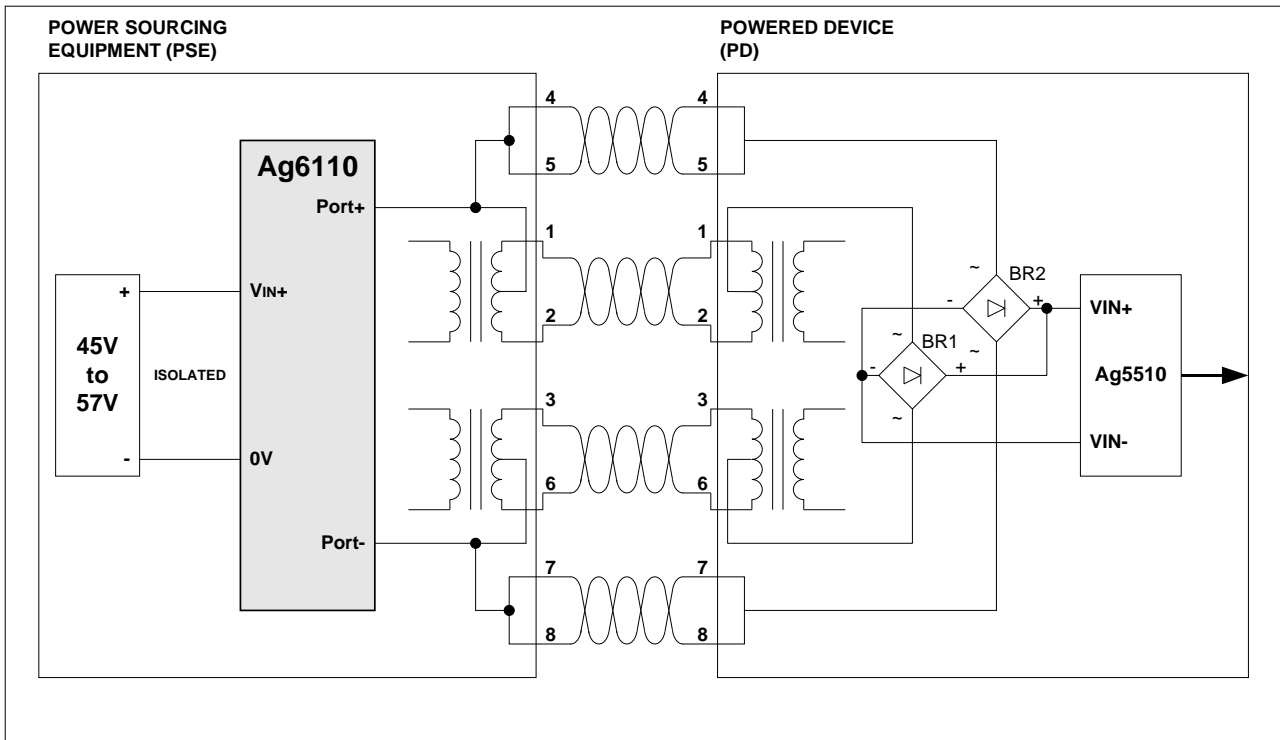

Figure 4: Typical Connection Diagram

## 6. Signature and Classification

The Ag6110 will automatically perform the Signature and Classification, Figure 5 shows the timing sequence for a Type 1 Powered Device (PD) and Figure 6 shows the timing sequence for a Type 2 PD.

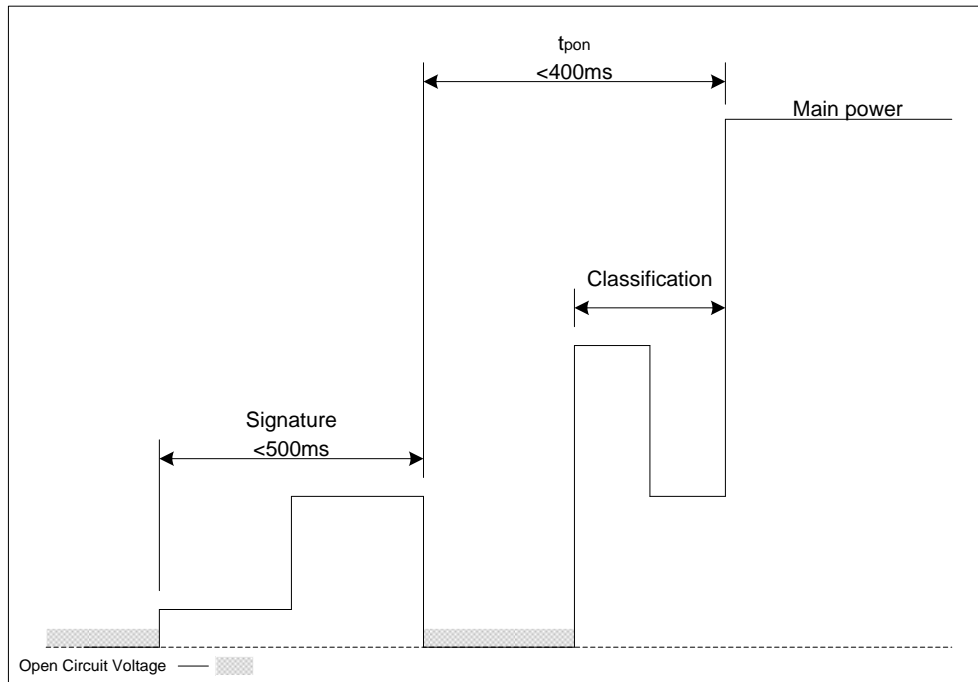

Figure 5: Signature, Class and Turn-On Timing - Type 1 PD

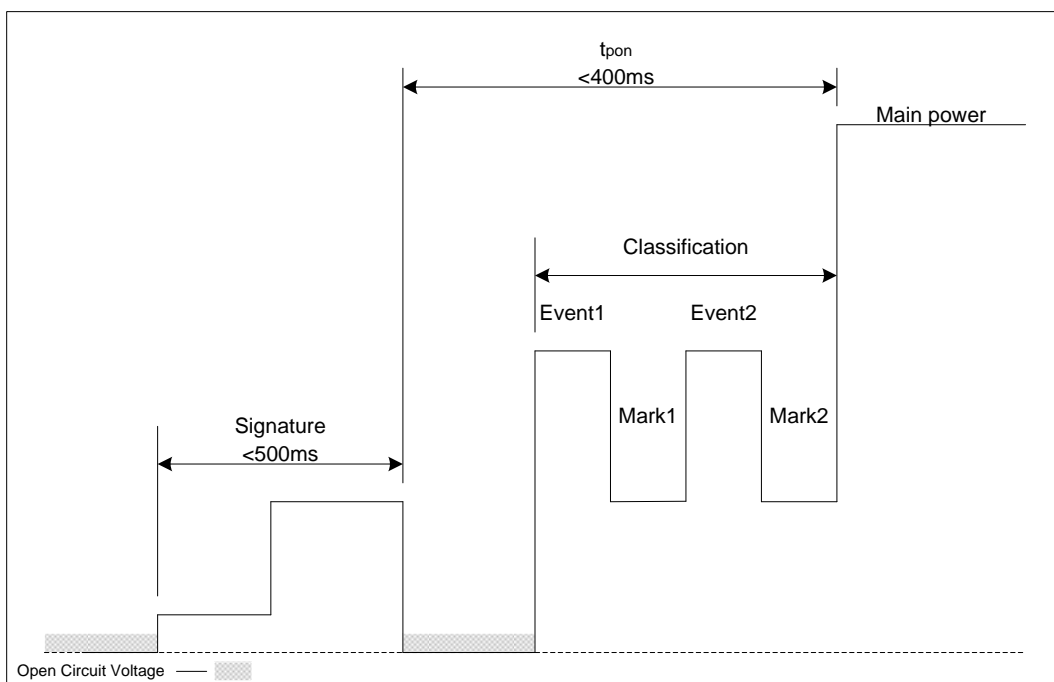

Figure 6: Signature, Class and Turn-On Timing - Type 2 PD

The IEEE802.3at separates the power handling into two basic categories “Type 1” and “Type 2”. In simple terms Type 1 handles power requirements up to 15.4W and is comparable with the IEEE802.3af specification. Type 2 handles the power levels above this, which is commonly referred to as POE+. The Ag6110 has been designed to be used with systems that present Class 5 and require Ultra PoE power levels.

## 6.1 Signature Detection

To ensure that the Ag6110 does not apply power to a non PoE enabled device the Port output first checks for a valid PoE signature. The PD should present a nominal 25kΩ (23.75kΩ to 26.25kΩ) Signature resistance; if the Ag6110 does not see a valid signature then it will disconnect, wait approximately 2 seconds then try again, see Figure 7 below.

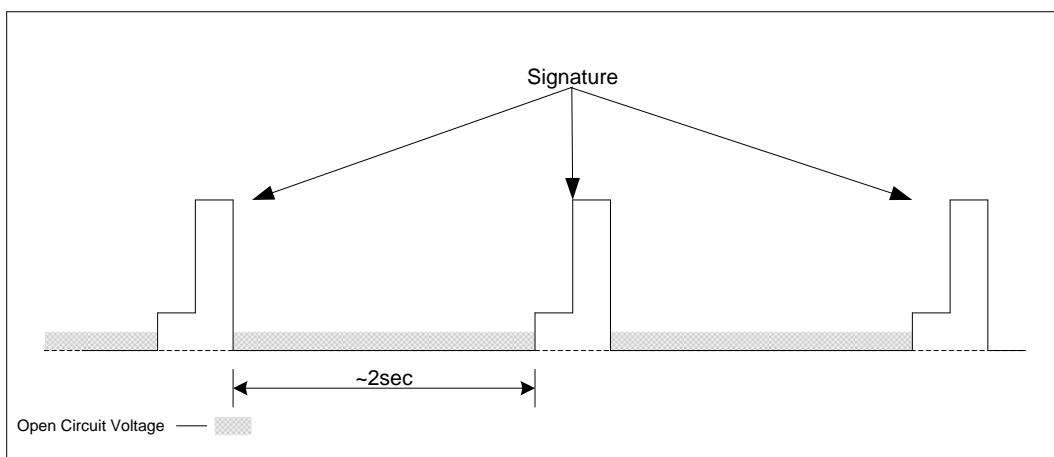

Figure 7: Signature Cycle Time

## 6.2 Classification

On completion of a valid signature, the Ag6110 will then interrogate the PD to see if a classification signature is present. The classification signature is used to determine the amount of power the PD will draw and limits the output power accordingly (see Table 2). It is optional for the PD to present a classification signature and the Ag6110 will default to Class 0 if the PD does not present one. If the Ag6110 sees a current over 65mA, it will detect this as ‘Over Current’ and will retry the signature after a 2 second delay.

Table 2 shows the measured current limits that the Ag6110 uses to assign a classification value.

Measured Current	Classification
0mA to 6.5mA	Class 0
>6.5mA to 14.5mA	Class 1
>14.5mA to 23mA	Class 2
>23mA to 33mA	Class 3
>33mA to 48mA	Class 4
48mA to 65mA	Class 5

Table 2: Classification Table

## 6.3 Maintain Power Signature

On successful completion of a valid signature (and classification) the Ag6110 will apply main power to the Port output and the STATUS output will go to Logic 1.

Once main power has been applied, the Ag6110 will constantly monitor the PD to ensure that it is still connected; this is referred to as the Maintain Power Signature (MPS).

The Ag6110 uses the dc detection method of MPS and will remove power if the current drawn falls below the detect threshold. If the Ag6110 Port output current is  $\geq 10\text{mA}$  the output will remain on. If the Port output current is  $\leq 5\text{mA}$  the output will be turned off and the Ag6110 will return to the signature cycle (looking for a valid signature).

## 6.4 Output Current Limits

The Ag6110 has two over current limits - Current Limit 1\* and Current Limit 2\*.

The Ag6110 will allow the Port output to exceed Current Limit 1 (but not Current Limit 2) for a short duration –  $T_{LIM1}^*$ . If the Port output continues to exceed Current Limit 1; the output power will be removed and the STATUS output will indicate an over-current fault (See Section 8 – STATUS Output).

If the output exceeds Current Limit 2, the Ag6110 will remove power (without waiting for  $T_{LIM}$ ) and the STATUS output will indicate an over-current fault.

\*Note: See Section 9.3 Electrical Characteristics

## 6.5 Output Power

The Ag6110 is capable of delivering up to 74W, when supplied with its maximum input voltage of 57V.

Please note this is not the power available at the input of the Powered Device (PD). There are cable, connector and polarity protection losses to be taken into account.

## 6.6 High Power Options

Figures 8a and 8b show typical application diagrams for the Ag6110 connected to the Ag5510 (60W Powered Device).

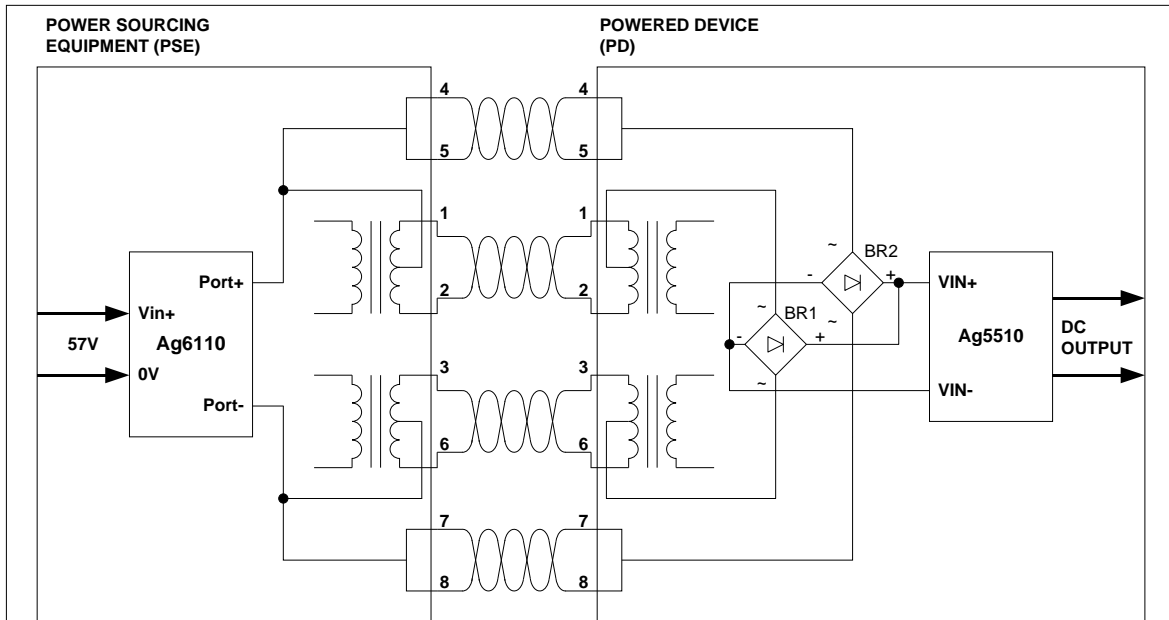

Figure 8a – Typical Application Diagram for Ag6110 using 10/100BASE-T

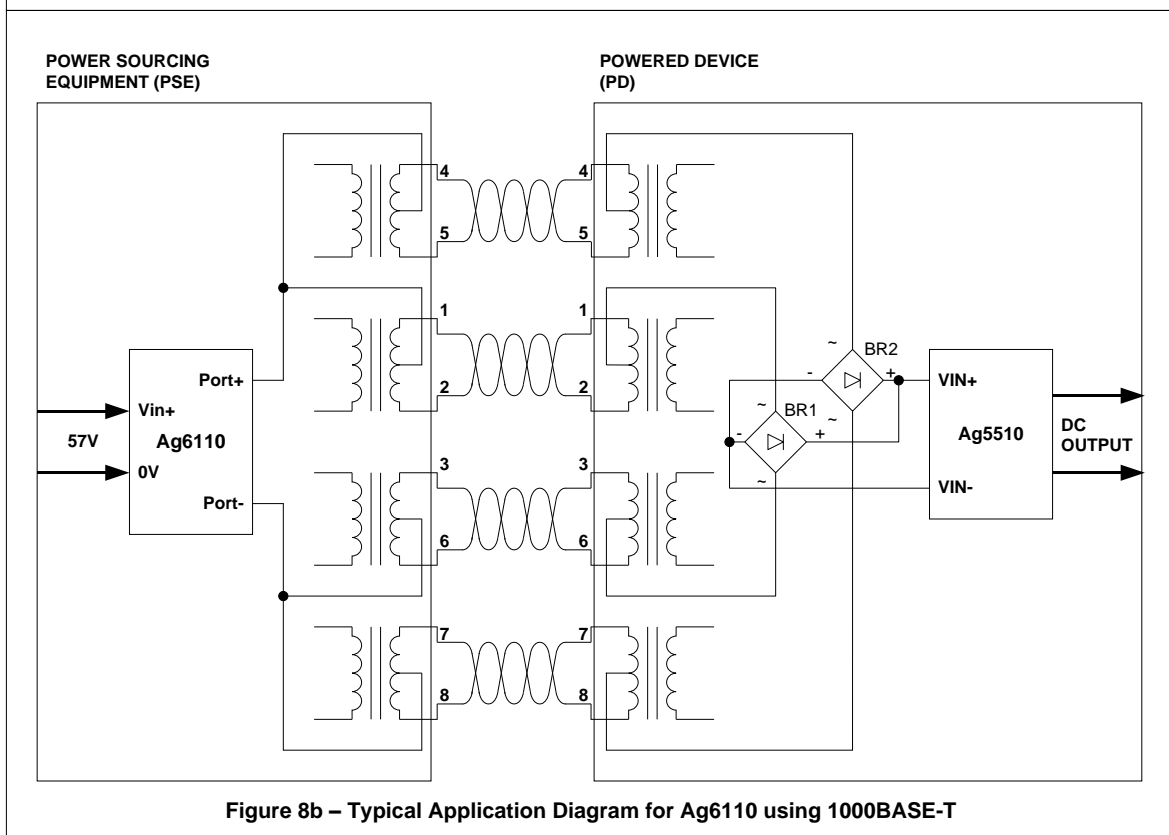

Figure 8b – Typical Application Diagram for Ag6110 using 1000BASE-T

Figure 8: Ag6110 Typical High Power Application Drawing

## 7. STATUS Output

The STATUS output pin is at Logic 0 when the Port output is disconnected. After completion of a valid signature (and classification) the STATUS output will go to Logic 1 at the same time as the Port output applies main power.

When the Port output is disconnected the STATUS output will go to Logic 0, see Figure 9.

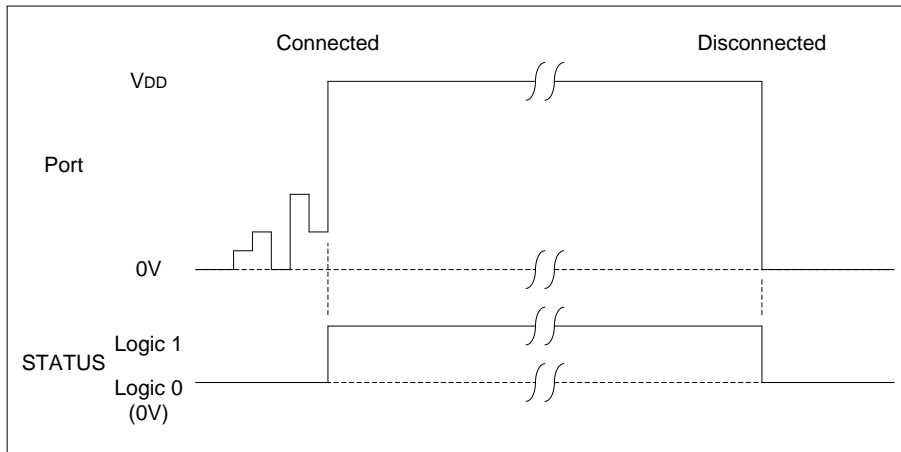

Figure 9: STATUS Output at Port Connect and Disconnect

In addition to the STATUS output reporting when the Port output is connected or disconnected, the STATUS output also reports when a fault has been detected.

When a short circuit fault is applied to the Port output, the STATUS output goes to Logic 0 for 100ms, then generating one 100ms pulse, before returning to Logic 0, see Figure 10.

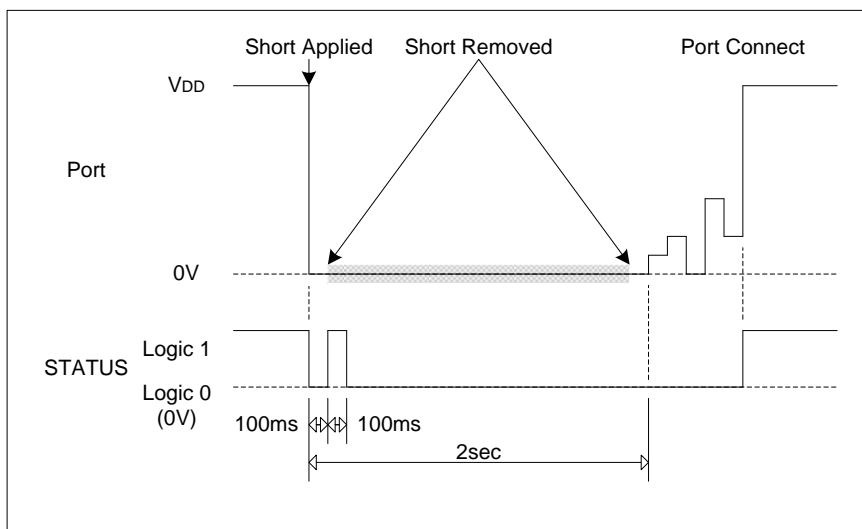

Figure 10: STATUS Output when a Short Circuit is applied to the Output Port

In the example shown in Figure 10, the short circuit is removed at some point before the next Signature and Classification and the Ag6110 resumes normal operation. If the short circuit is not removed the Ag6110 will not pass the next Signature and the Port output will remain off.

When an over-current fault is applied to the Port output, the STATUS output goes to Logic 0 for 100ms, then generating two 100ms pulses, before returning to Logic 0, see Figure 11.

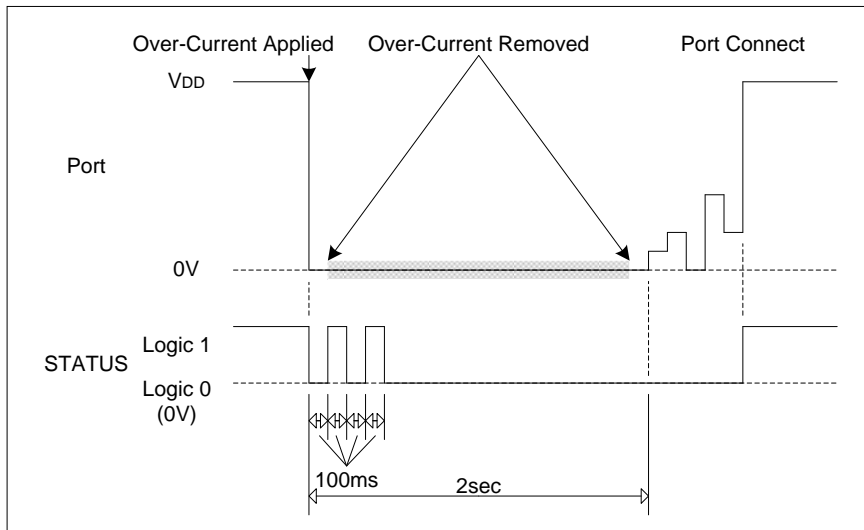

Figure 11: STATUS Output when an Over-Current is applied to the Output Port

In the example shown in Figure 11, the over-current is removed at some point before the next Signature and Classification and the Ag6110 resumes normal operation. If the short circuit is not removed the Ag6110 will start up again and repeat the fault shutdown cycle until the over-current fault is removed, see Figure 12.

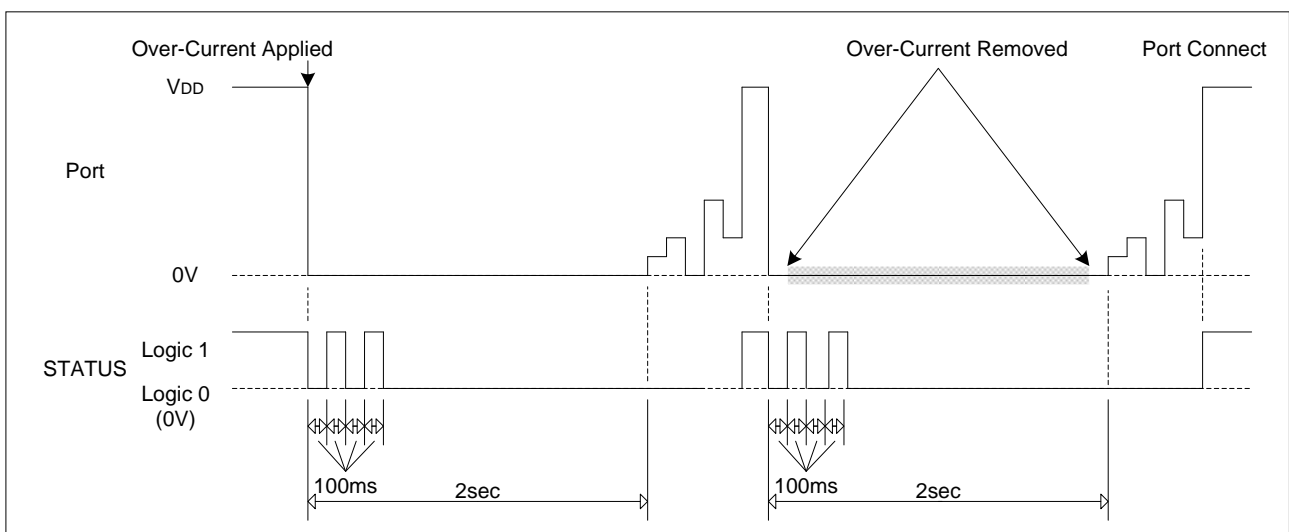

Figure 12: STATUS Output when an Over-Current fault is not removed

The Ag6110 STATUS output pin has a limited drive capability. This is sufficient to drive a logic input, but does not have enough power to continually drive an LED. Figure 13 shows a simple circuit to drive an LED from the STATUS output. Over driving the STATUS output can result in damage to the internal 3.5V reference supply.

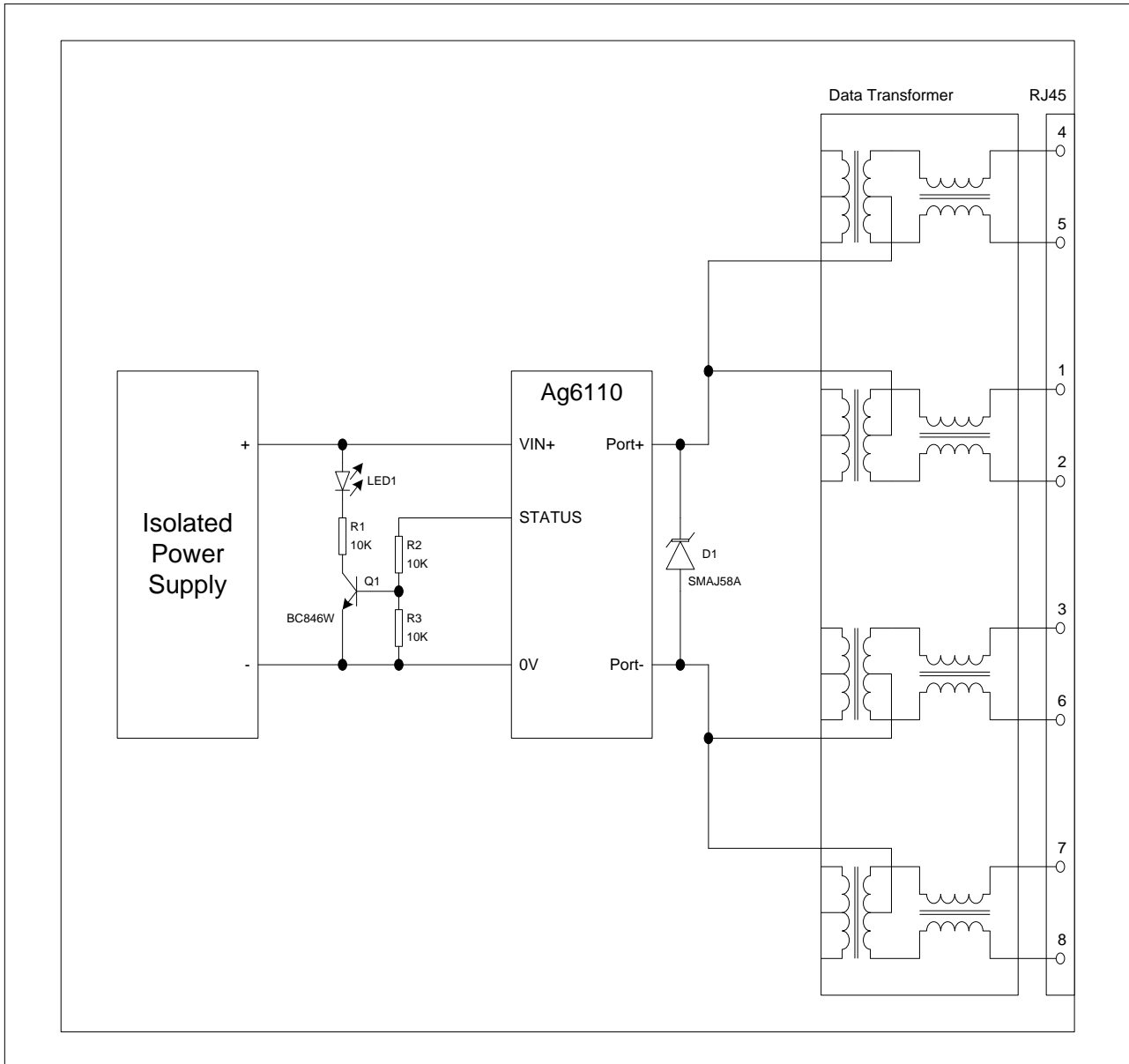

Figure 13: STATUS Output LED drive circuit

## 8. Protection

### 8.1 Input Protection

The Ag6110 has a built-in Tranzorb diode across its input, to protect the module from transients from the power supply. For further protection we would recommend a 2A slow blow fuse to be fitted in line with the positive input rail due to the high power capability of the power supply as described in section 5.1 and shown in Figure 3.

### 8.2 Output Short-Circuit Protection

In addition to the over-current protection the Ag6110 has built-in output short-circuit protection.

If the Port output is shorted, the Ag6110 will limit the current and remove the power, the STATUS output will indicate a short-circuit fault.

To further protect the output from voltage transients on the cable and over-voltages exceeding the 80V maximum rated surge voltage, we recommend connecting a Tranzorb diode across the output. An example of this inexpensive but effective solution is shown above in Figure 13.

## 9. Electrical Characteristics

### 9.1 Absolute Maximum Ratings<sup>1</sup>

	Parameter	Symbol	Min	Max	Units
1	DC Supply Voltage	$V_{DD}$	-0.3	60	V
2	Storage Temperature	$T_S$	-40	+100	$^{\circ}C$

Note 1: Exceeding the above ratings may cause permanent damage to the product. Functional operation under these conditions is not implied. Maximum ratings assume free airflow.

### 9.2 Recommended Operating Conditions

	Parameter	Symbol	Min	Typ	Max	Units
1	Input Supply Voltage	$V_{DD} (Type1)$	45		57	V
		$V_{DD} (Type2)$	50		57	V
		$V_{DD} (Class5)$	54		57	V
2	Ag6110 Operating Temperature	$T_{OP}$	-20	25	70	$T_a / ^{\circ}C$

## 9.3 Electrical Characteristics

	Parameter	Sym	Min	Typ	Max	Units	Condition
1	V <sub>DD</sub> Idle Supply Current	I <sub>DD</sub>		8	15	mA	
2	Signature Detection Voltage	V <sub>SIGL</sub> V <sub>SIGH</sub>	2.7	4.5 9	10.1	V V	
3	Minimum Valid Signature	R <sub>SIGL</sub>	15			kΩ	
4	Maximum Valid Signature	R <sub>SIGH</sub>			32	kΩ	
5	Classification Voltage	V <sub>CLASS</sub>	14.5		20.5	V	
6	Classification Mark Voltage	V <sub>MARK</sub>	6.9		10	V	
7	Classification Threshold Current	I <sub>CLASS</sub>	5.5 13.5 21.5 31.5 45.2 52	6.5 14.5 23 33 48 55	7.5 15.5 24.5 34.9 50.8 65	mA mA mA mA mA mA	Class 0 - 1 Class 1 - 2 Class 2 - 3 Class 3 - 4 Class 4 <sup>1</sup> - 5 Class 5 - Over-current
8	Maintain Power Signature	V <sub>MPS</sub>	5		10	mA	
9	Maximum Output Power @ 57V*	P <sub>MAX</sub>	69	21 74		W W	Type 1 Type 2
10	Current Limit 1	I <sub>LIM1</sub>		375 1320		mA mA	Type 1 Type 2
11	Current Limit 2	I <sub>LIM2</sub>		475 1420		mA mA	Type 1 Type 2
12	Current Limit 1 Cut-Off Time	T <sub>LIM1</sub>	50 10			ms ms	Type 1 Type 2
13	STATUS Output	V <sub>OH</sub> V <sub>OL</sub>		3.3 0.3		V V	@ -3mA @ 3mA

Note1: If a PD presents Class 4 or 5 the Ag6110 will allow ~1.32A current draw before detecting an overcurrent.

\* Typical power output with a 57V input – Not guaranteed.

## 10. Package

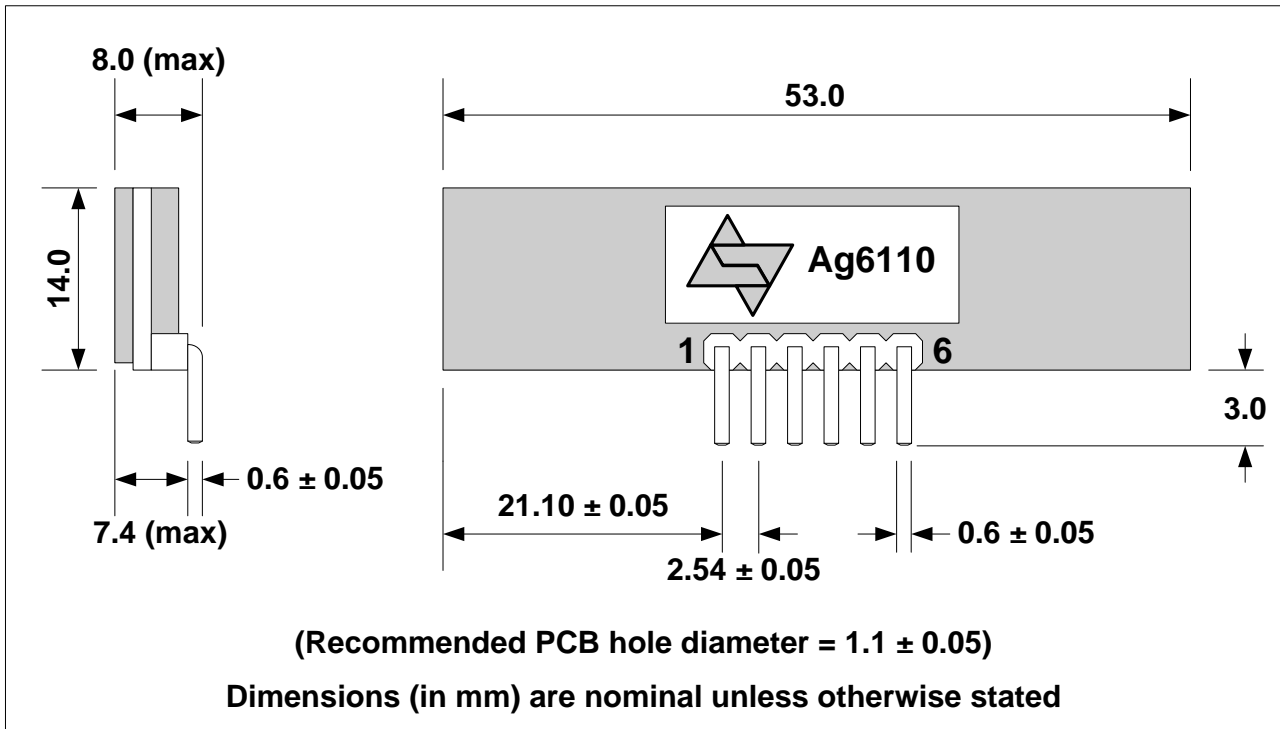

Information published in this datasheet is believed to be correct and accurate. Silver Telecom assumes no liability for errors which may occur or for liability otherwise arising out of use of this information or infringement of patents which may occur as a result of such use. No license is granted by this document under patents owned by Silver Telecom or licensed from third parties by Silver Telecom. The products, their specification and information appearing in this document are subject to change by Silver Telecom without notice.